

# **Patio II™**

## **OWNER'S MANUAL**

### **Thermal Engineering Corporation**

P.O. Box 868, Columbia, South Carolina 29202-0868  
2741 The Boulevard, Columbia, South Carolina 29209  
Telephone: (803) 783-0750 Toll-free (800) 331-0097  
Fax : (803) 783-0756 Toll-free fax: (888) 581-0286

Website: [www.tecinfrared.com](http://www.tecinfrared.com)



Revised 08/04 -- Z21.58b/CGA1.6b-2002

# Warnings

## For Your Safety

If you smell gas:

1. Shut off gas to the appliance.
2. Extinguish any open flame.
3. Open lid.
4. If odor continues, immediately call your gas supplier or your fire department.

## For Your Safety

1. Do not store or use gasoline or other flammable vapors or liquids in the vicinity of this or any other appliance.
2. An LP cylinder not connected for use shall not be stored in the vicinity of this or any other appliance.

# Warnings to Consumer

DO NOT INSTALL OR OPERATE THIS APPLIANCE WITHOUT HAVING CAREFULLY READ THIS MANUAL. FOR FUTURE REFERENCE, HAVE THIS MANUAL AVAILABLE WHILE USING THIS APPLIANCE AND ALWAYS FOLLOW THE INSTRUCTIONS PROVIDED.

NEVER ATTEMPT TO MAKE CONVERSIONS OR MODIFICATIONS TO YOUR GRILL WITHOUT FIRST OBTAINING WRITTEN INSTRUCTIONS FROM THERMAL ENGINEERING CORPORATION.

DO NOT STORE A SPARE GAS CYLINDER UNDER OR WITHIN 15 FEET OF THIS GRILL OR ANY OTHER OPEN FLAME, HEAT PRODUCING APPLIANCE OR HEAT SOURCE.

DO NOT ALLOW YOUR LP GAS CYLINDER TO BE FILLED BEYOND 3/4 FULL.

**WARNING:** FAILURE TO FOLLOW THESE INSTRUCTIONS CAN RESULT IN A FIRE CAUSING DEATH OR SERIOUS INJURY OR PROPERTY DAMAGE.

# Notices

## Notice to Consumer

PRIOR TO INSTALLING AND USING THIS APPLIANCE, READ THIS MANUAL FULLY AND CAREFULLY. RETAIN THIS MANUAL FOR FUTURE REFERENCE AND HAVE AVAILABLE AT ALL TIMES. ENSURE THAT ALL PERSONS OPERATING THIS EQUIPMENT CAREFULLY READ AND BECOME FAMILIAR WITH THE INFORMATION IN THIS MANUAL.

THIS UNIT HAS BEEN CAREFULLY INSPECTED AND PACKAGED AT THE FACTORY PRIOR TO SHIPMENT. UPON ARRIVAL, INSPECT THE APPLIANCE CAREFULLY FOR ANY CONCEALED DAMAGE. IMMEDIATELY REPORT ANY DAMAGE TO RETAILER.

SHOULD YOU HAVE ANY QUESTIONS REGARDING OPERATION OR USE OF THIS APPLIANCE CONTACT THERMAL ENGINEERING CORPORATION AT 803-783-0750 OR 1-800-331-0097.

## Notice to Installer

INSTALLATION MUST CONFORM TO LOCAL CODES OR THE NATIONAL FUEL GAS CODE, ANSI Z223.1/NFPA 54. IN CANADA, INSTALLATION OF THIS PRODUCT SHOULD BE IN ACCORDANCE WITH THE CAN/CGA-B149.1 NATURAL GAS AND PROPANE INSTALLATION CODE. FOLLOWING INSTALLATION, LEAVE THIS OPERATIONS MANUAL WITH THE CONSUMER FOR FUTURE REFERENCE. THIS APPLIANCE IS NOT INTENDED FOR USE ON RECREATIONAL VEHICLES AND/OR BOATS.



NATIONALLY REGISTERED TESTING LABORATORY

U.S. Patent # 4886044  
U.S. Patent # 4321857  
Des. 266,050

© Thermal Engineering Corporation, Revised 08/04 -- Z21.58b/CGA1.6b-2002

# Lifetime Limited Warranty

## EXPRESS WARRANTIES

Thermal Engineering Corporation (TEC) warrants this grill to be free of defects in material and workmanship when subjected to normal domestic use and service from the date of purchase as follows:

### LIFETIME

Other than cooking grids and stainless burner components, all stainless steel components are warranted indefinitely.

### FIVE YEARS

All painted structures, burner boxes, and stainless burner components are warranted against rust-through for five years. Surface rust, which may occur because of exposure to certain atmospheric conditions and contaminants, is not covered for five years.

### ONE YEAR

First year In home service from Authorized TEC Dealer or Service Representative. Maximum one hour per visit. Exterior painted structures are warranted against surface rust for one year.

### TEN YEARS

Burner ceramics and all other components not covered by the warranties above are warranted for ten years.

**PLEASE NOTE:** THIS UNIT IS NOT DESIGNED OR DESIGN-CERTIFIED FOR BUILD-IN USE. TEC MAKES NO WARRANTY AGAINST RUST TO ANY DEGREE TO THE EXTERIOR OF PAINTED UNITS BUILT INTO ENCLOSURES.

## UNDER THIS WARRANTY

We will, at our option, repair or replace any component part deemed by TEC to be defective when returned to the TEC factory, freight prepaid, within the warranty period. Prior to authorization of repair or replacement, you must supply the date of original purchase and serial number of your grill.

This warranty excludes damage caused by failure to follow the instructions in your Owner's Manual or alteration of the grill's structure or components, or from operator abuse, negligence or accident.

## DISCLAIMER OF IMPLIED WARRANTIES

This warranty excludes incidental and consequential damages. Except as stated above, all other warranties, including *implied warranties of merchantability and fitness for a particular purpose*, are excluded.

If you have questions concerning this warranty, please call us at 1-800-331-0097.

### THERMAL ENGINEERING CORPORATION

P.O. Box 868, Columbia, South Carolina 29202-0868  
2741 The Boulevard, Columbia, South Carolina 29209  
Telephone: (803) 783-0750 Toll free: (800) 331-0097  
Facsimile: (803) 783-0756 Toll free: (888) 581-0286  
Website: [www.tecinfrared.com](http://www.tecinfrared.com)

<b>MODEL #:</b> _____
<b>SERIAL #:</b> _____ (See rating plate on back panel.)
<b>DEALER NAME:</b> _____
<b>DEALER TELEPHONE:</b> _____

(Complete the above information for future reference.)

Dear TEC Infra-Red Grill Owner:

Thank you for selecting a TEC Infra-Red grill. You're among a select group who truly appreciate fine cooking and demand the best and we at TEC appreciate your confidence in our products.

I know you'll be pleased with your grill's performance. Over the years, we've invested great resources in developing grills that are truly unique in terms of their sturdy, long-lasting construction, their cooking versatility and TEC's innovative infra-red cooking processes.

We've developed this manual to give you an overview of your grill and to help you get the most from it. We've included some cooking guidelines for you to use until you develop your own techniques. We've also included vital information about how to set up, operate and maintain your grill safely and correctly, so I urge you to read it carefully before first using your grill. If, after reviewing this information, you have any questions whatsoever, please call your Authorized TEC Dealer or our Customer Service Department at 1-800-331-0097 for help.

As I'm sure you know, we also offer a complete line of accessories that afford you a wide range of opportunities for new and interesting uses of your grill. Some of them, like our rotisserie, are options familiar to everyone. Others, like our deep fryer and wok, are truly unique enhancements that allow you to be adventuresome and inventive with your grill. Appendix A to this owner's manual explains the uses of these accessories. Your dealer also can tell you more about all the accessories we offer and their many uses.

If you have comments, suggestions, or even compliments, please pass them along to us. We are continually in search of ways we can improve our customers' experiences with their grills, starting when they first remove them from the box and continuing as they use them over the years. Hearing what you feel we could improve, as well as what you especially like about our products and services, is essential to this effort. To facilitate this feedback, a Product Registration Form is included with your grill. We would be grateful if you would take a few minutes to complete it and send it to us -- after you've used your new TEC a few times. We'll send you a free TEC apron as a token of our appreciation!

Happy grilling!

Best regards,

David O'Kelly  
*President*

THERMAL ENGINEERING CORPORATION  
Consumer and Commercial Products Division

# Contents

<b>Installation .....</b>	<b>4</b>
<b>Assembly .....</b>	<b>5</b>
<b>Gas Connection .....</b>	<b>7</b>
<b>Operation .....</b>	<b>10</b>
<b>Infra-Red Cooking .....</b>	<b>13</b>
<b>Care, Cleaning and Maintenance..</b>	<b>15</b>
Protection of burners	
Cleaning	
Replacement parts	
Heat shield removal procedures	
<b>Appendix A - Accessories .....</b>	<b>17</b>
<b>Appendix B - Replacement Parts ..</b>	<b>23</b>
<b>Appendix C - Troubleshooting.....</b>	<b>24</b>

# Installation

## General Overview

**WARNING:** THIS GRILL IS DESIGNED CERTIFIED FOR USE OUTDOORS ONLY.

THIS GRILL SHOULD NOT BE USED IN A BUILDING, GARAGE OR OTHER ENCLOSED AREA AND IS NOT INTENDED FOR USE ON RECREATIONAL VEHICLES OR BOATS.

DO NOT USE THIS APPLIANCE UNDER OVERHEAD COMBUSTIBLE CONSTRUCTION.

## Permanent Installation

The installation of your grill must conform to local codes or, in absence of local codes, the National Fuel Gas Code ANSI Z223.1/NFPA 54. In Canada, the installation must conform to local codes and/or the Natural Gas and Propane Installation Code CAN/CGA-B149.1.

The Post Base is constructed of stainless steel, which is highly corrosion resistant. However, a suitable means of corrosion protection should be used, as necessary, due to corrosive conditions at the installations site.

If you are installing your grill on the optional In-ground Post Base or the Bolt-down Post Base, it should be located so the ventilation louvers remain clear of all obstructions. The louvers are located in the front surface of the Grill's Housing and at the rear of the Roll Back Hood. Any accumulation of debris will restrict the flow of combustion and/or ventilation air, and may result in improper burner operation or overheating. (See Table A.1 for clearance specifications.) Installation procedures relating to gas connections for permanent installations can be found in the Gas Connection section of this manual.

# Installation continued

COMBUSTIBLE CONSTRUCTION	
Sides	12"
Back	12"

**Table A.1** Clearance Specifications

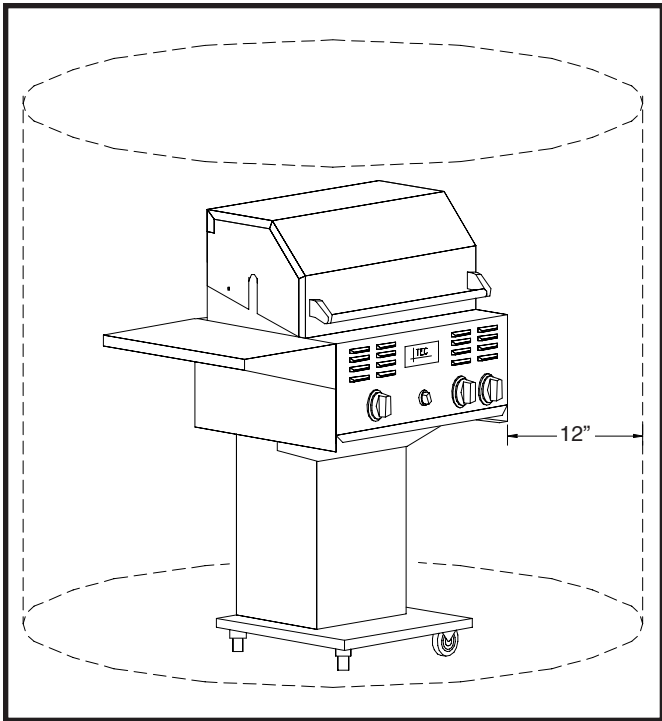

**Figure 1.** Clearance Specifications

The Post Base is designed to be installed in a bed of concrete to a depth of 17 1/2". The height of the grill cooking surface should be roughly 38 1/2" from the ground. The gas connection is located on the left side of the post. The gas connection is 3/8" SAE 45° female flare.

**WARNING:** THIS OUTDOOR COOKING GAS APPLIANCE SHALL NOT BE USED UNDER OVERHEAD COMBUSTIBLE CONSTRUCTION.

# Assembly

## General Overview

The Patio II™ gas grill is designed for easy assembly. The Patio II™ grill is available with three base mounting options. Assembly procedures for each of these options follow.

## Tools Required

- Phillips screwdriver (#2)

## Side Shelf

1. Remove the Side Shelf from shipping box.
2. Remove the upper (2) 1/4 - 20 x 5/8 long Phillips-head bolts from the grill housing.
3. Loosen the lower (2) Phillips-head bolts in the grill housing. **Do not remove the lower bolts.**
4. Mount the Side Shelf onto the lower bolts loosened in step 3 above.
5. Insert (2) Phillips-head bolts into the upper holes.
6. Tighten all (4) bolts securely.

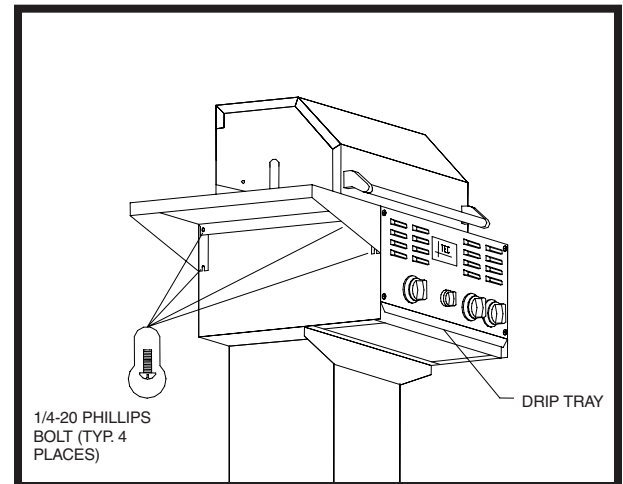

**Figure 2.** Side Shelf (new style)

# Assembly continued

## Pedestal Base

Assemble the Pedestal Base and mount the Grill Housing as follows. The required hardware is tied to the top back corner of the Pedestal Base in a plastic bag.

1. Remove the Pedestal Base from the packaging materials and set it on a level surface.
2. Remove the Gusset from the tank storage cavity and unpackage it. Place Gusset across front top of Pedestal Base with top flange facing away from the front of the Pedestal Base. Align the (6) holes and insert (6) 1/4"-20 Carriage bolts through the holes with the threads pointed into the tank storage cavity. Fasten the bolts with a flat washer followed by a lock washer, followed by a 1/4" nut.
3. Remove the Drip Tray from the Grill Housing. Place the Grill Housing on the Pedestal Base and align the square holes in the Housing with the round holes in the Base.
4. Fasten the Housing to the Base with the supplied hardware. Make sure the carriage bolt threads are on the outside of the grill. (Hardware needed: Six (6) 1/4"-20 x 1/2" L carriage bolts, twelve (12) 1/4" flat washers, six (6) 1/4" lock washers and four (6) 1/4"-20 nuts.)
5. Replace the Drip Tray after tightening the fasteners. (See Figure 3.)

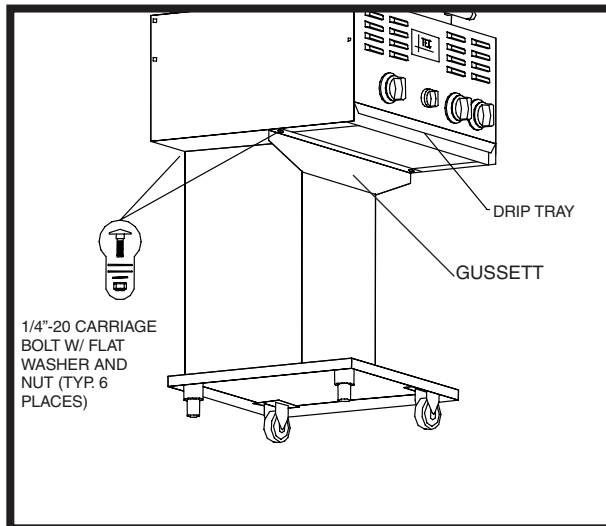

**Figure 3.** Pedestal Base

## In-Ground Post Base & Bolt-Down Base

1. Install the In-ground or Bolt-down Post Base in accordance with the instructions accompanying the Post Base. (See Figures 4 & 5.)
2. Remove the Drip Tray from the Grill Housing. Place the Grill Housing on the properly installed Post Base and align the round mounting holes in the Base with the square mounting holes in the Housing.
3. Fasten the Housing to the Base with the supplied hardware. (Hardware needed: Four (4) 1/4" - 20 x 1/2" L carriage bolts, eight (8) 1/4" flat washers, four (4) 1/4" lock washers and four (4) 1/4"-20 nuts.) (See Figure 4 or Figure 5.)
4. Replace the Drip Tray after tightening the fasteners.

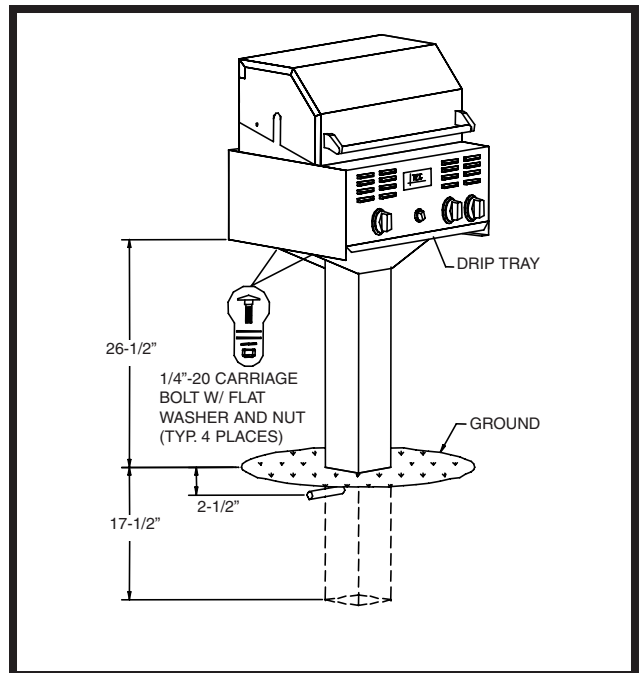

**Figure 4.** In-ground Post Base



# Assembly continued

## Cooking Grids and Warming Rack

1. Remove the Cooking Grids and Warming Rack from the packaging materials.
2. Set the Cooking Grids in place with the open side of the channels facing up and the holes toward the rear of the grill. Set the Warming Rack in place inside the Roll Back Hood.

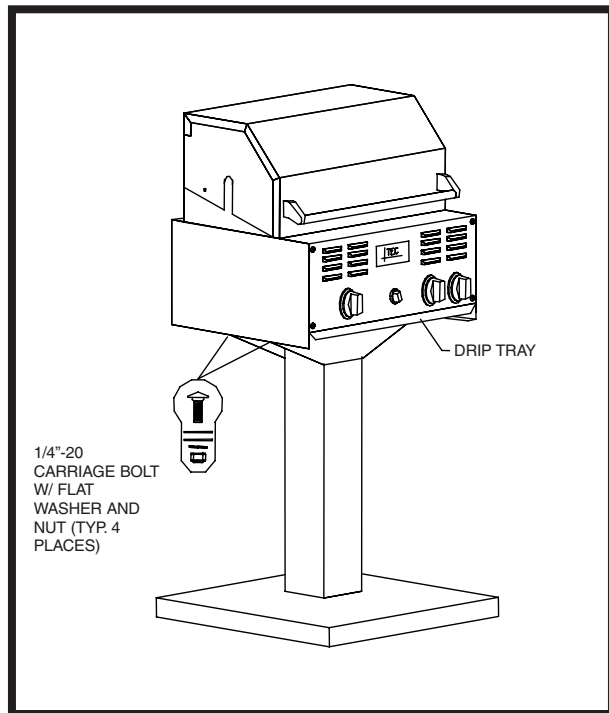

**Figure 5.** Bolt-down Post Base

# Gas Connection

## General Overview

**WARNING:** WHEN PURCHASED FOR USE WITH LP GAS, THE PATIO GRILL COMES WITH A REGULATOR ASSEMBLY THAT USES A MARSHALL BRASS GAS COUPLING DEVICE. THIS QUICK-CONNECT TYPE DEVICE SHOULD ONLY BE USED WITH A SHERWOOD TANK VALVE, PART #PV-3349.

**WARNING:** THE GAS SUPPLY HOSE SHOULD BE INSPECTED PRIOR TO EACH USE. DO NOT USE A GAS HOSE THAT HAS ABRASION, CUTS OR EXCESSIVE WEAR. IF ABRASION, CUTS OR EXCESSIVE WEAR IS EVIDENT, THE GAS SUPPLY HOSE MUST BE REPLACED BEFORE USE. REPLACEMENT ASSEMBLY MUST BE SPECIFIED BY TEC.

**WARNING:** WHEN YOUR GRILL IS STORED INDOORS, REMOVE AND STORE THE LP GAS CYLINDER OUTDOORS IN A PROTECTED, COOL AND DRY LOCATION OUT OF REACH OF CHILDREN. THE CYLINDER SHOULD NOT BE STORED IN A BUILDING, GARAGE OR ANY OTHER ENCLOSED AREA.

Follow the procedures outlined in this section closely to ensure safe and proper grill operation. The Patio II™ grill is offered in one of two gas configurations: LP or Natural gas. The pressure regulator and hose used for the LP gas configuration varies depending on the type of base used. Reference Table A.2 on page 8 for regulator specification. Grills that do not use LP gas with standard 20 lb. LP cylinder must be installed by qualified personnel. This includes all Natural gas and permanently installed units. Gas regulators specified by TEC should be used at all times. For gas supply specifications refer to Table A.2 or see rating plate located on the back of the grill housing.

## LP Gas Cylinder Safety

**NOTICE:** AN LP GAS CYLINDER IS NOT PROVIDED FROM THE FACTORY WITH THIS GRILL. HOWEVER, ONLY APPROVED 20 LB. LP GAS CYLINDERS CONSTRUCTED AND MARKED IN ACCORDANCE WITH THE SPECIFICATIONS FOR LP GAS CYLINDERS OF THE U.S. DEPARTMENT OF TRANSPORTATION (D.O.T) OR NATIONAL STANDARD OF CANADA, CAN/CGA-B339, CYLINDERS, SPHERES AND TUBES FOR THE TRANSPORTATION OF DANGEROUS GOODS; AND COMMISSION, SHOULD BE USED. ALL APPROVED CYLINDERS MUST HAVE AN INTEGRAL COLLAR

# Gas Connection continued

DESIGN TO PROTECT THE CYLINDER VALVE FROM DAMAGE. DO NOT USE OR TRY TO REPAIR A DAMAGED LP GAS CYLINDER AT ANY TIME. CONTACT YOUR LOCAL LP GAS SUPPLIER FOR REPLACEMENT. ALSO, YOU SHOULD ALWAYS OBSERVE THE FOLLOWING PRECAUTIONS:

- Store any spare or extra gas cylinders at least 15 feet from this grill or other open flame, heat-producing appliance or heat source.
- Do not fill your gas cylinder beyond  $\frac{3}{4}$  full.
- Gas cylinders come with a pressure relief valve. If a cylinder is subjected to excess heat, the relief valve will open and let highly flammable gas vapor and/or liquid escape. Therefore, do not store gas cylinders near an open flame or source of heat. Store cylinders only in well ventilated areas. Failure to follow these precautions could result in a fire causing death or serious injury or property damage.

## Installing Your LP Gas Cylinder

**WARNING:** THE GAS SUPPLY HOSE SHOULD BE INSPECTED PRIOR TO USE. DO NOT USE A REGULATOR WITH AN ATTACHED HOSE THAT HAS AN ABRASION OR EXCESSIVE WEAR ON THE HOSE.

**NOTICE:** FOR YOUR SAFETY, ONLY USE THE REGULATOR AND HOSE ASSEMBLY PROVIDED AS ORIGINAL EQUIPMENT WITH YOUR GRILL.

**NOTICE:** A FIRE EXTINGUISHER FOR CLASS A, B, C & D FIRES SHOULD BE READILY AVAILABLE AT ALL TIMES.

**Table A.2.** Gas Supply Specifications (revised)

GAS, REGULATOR AND BASE TYPE	SUPPLY PRESSURE (IN. WC (kPa), MAX/MIN)	OPERATING PRESSURE (IN. WC (kPa))	MAIN BURNER ORIFICE SIZE (DMS / DIA.)	BURNER OUTPUT (BTU/HR. (W)/EA.)
Natural model RV-47L (NG) stationary or post	14.0 (3.4)/5.0 (1.2)	4.0 (1.0)	46 (0.0810")	18,500 (5,422)
LP model RV-47L (LP) stationary or post	14.0 (3.4)/12.0 (3.0)	11.0 (2.7)	55 (0.0520")	18,500 (5,422)
LP model 150 w/hose pedestal	125 psi (861), max	11.0 (2.7)	55 (0.0520")	18,500 (5,422)

Be sure to set the gas cylinder upright so the Cylinder Valve is at the top. This will ensure proper vapor withdrawal.

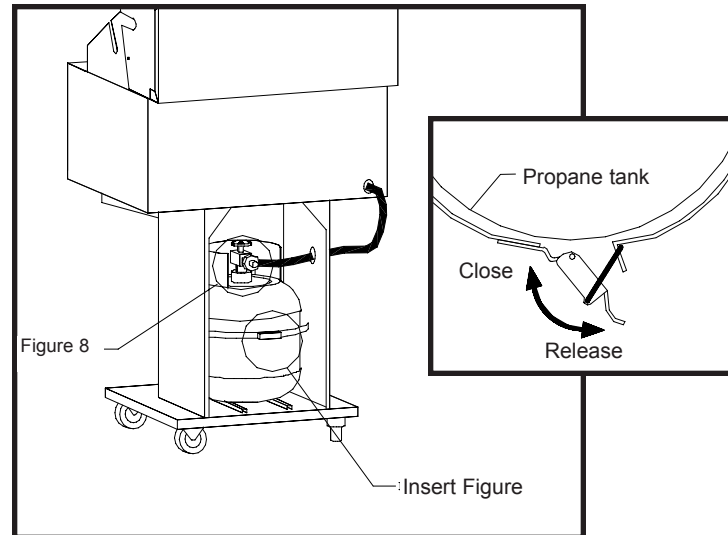

**Figure 7.** Gas Tank Placement

**WARNING:** KEEP THE VENTILATION OPENINGS OF THE CYLINDER ENCLOSURE FREE AND CLEAR OF DEBRIS.

### Procedure (See Figures 7 and 8):

1. In order to make sure the Cylinder Valve is fully closed, turn the Handwheel clockwise until it stops.
2. Turn all burner and pilot controls OFF.
3. Move your grill to an open area that's level.
4. Inspect the Coupling Nut, Nipple and Cylinder Valve. Look for any damage to threads, dirt or debris. Remove dirt or debris. Replace damaged parts prior to use.

## Gas Connection continued

5. Inspect Regulator and hose assembly. Look for any damage such as abrasions or holes, dirt or debris. Remove dirt or debris. Replace damaged parts prior to use.
6. Place the gas cylinder in the space provided in the base. (See Figure 7.) Remove the protective caps from Cylinder Valve in grill using the strap provided.
7. With the Regulator in your hand, insert the Nipple into the Cylinder Valve. (See Figure 8.) Make sure the Nipple is centered in the Cylinder Valve outlet. Make sure you do not cross-thread the connection. Tighten the coupling nut only by hand, do not use tools. As the connection begins to seal, you will feel a slight resistance. Turn the coupling nut about one-half to three quarters of a turn further to complete the connection. If you cannot complete the final connection, disconnect the regulator and repeat step 7. If you are still unable to complete the connection, replace the valve and regulator!

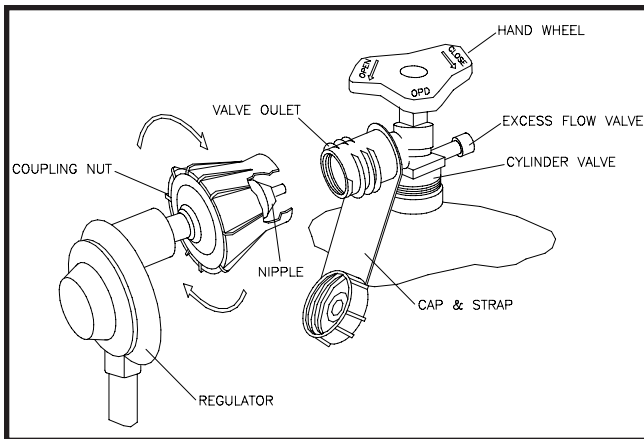

**Figure 8.** Coupling Assembly

## Removing Your LP GAS Cylinder

### Procedure:

1. Make sure burner and pilot output knobs are in the OFF position.
2. Close the Cylinder Valve by turning the Handwheel clockwise until it stops.
3. Release the latch and remove the cylinder from the grill.
4. Loosen the Coupling Nut by turning it counter-clockwise.

## Permanent Installation

**CAUTION:** GAS PIPING TO YOUR GRILL MUST BE IN ACCORDANCE WITH LOCAL CODES. IN THE ABSENCE OF LOCAL CODES, USE THE NATIONAL FUEL GAS CODE ANSI Z223.1/NFPA 54 (LATEST EDITION) OR CAN/CGA B-149.1 NATURAL GAS AND PROPANE INSTALLATION CODE.

**CAUTION:** THE GAS SUPPLY MUST BE TURNED OFF AT THE GRILL WHEN THIS APPLIANCE IS NOT IN USE.

When ordered for use with Natural gas, the Patio grill comes adjusted to operate with Natural gas. **Qualified personnel should install the gas line. A shut-off valve at the grill is required. This valve must be design-certified by the CSA.**

When using the optional Post Base with LP gas, you must use the regulator and separate hose supplied with the Post Base. Instructions are provided with the In-ground or Bolt-down Post Bases. Specifications for gas supply requirements are listed in Table A.2.

The grill and its individual shut-off valve must be disconnected from the gas supply piping system during any pressure testing of that system at test pressures in excess of 1/2 psi (3.5 kPa).

The grill must be isolated from the gas supply piping system by closing its individual manual shut-off valve during any pressure testing of the gas supply piping system at test pressures equal to or less than 1/2 psi (3.5 kPa).

## Gas Leak Test

**WARNING:** DO NOT USE OPEN FLAME TO PERFORM LEAK TEST!

**WARNING:** DO NOT ATTEMPT TO USE THE GRILL WHEN YOU SMELL GAS OR FAIL A GAS LEAK TEST.

Make sure there is no open flame near the grill during the test. Test for leaks every time the gas connection is disconnected.

### Procedure:

1. Turn all controls OFF.
2. Open the Gas Supply Valve slowly. Apply soapy water solution to all connections including factory connections.
3. Look for bubbles around the connections. If bubbles can be seen at connections, close the Valve and tighten the connections where the bubbles were found. If components are leaking because of damage, replace defective components. Then, repeat steps 1 and 2 until no leaks are present. Make sure you do not over-tighten the connections.
4. Proceed with grill use.

# Operation

## General Overview

**NOTICE:** YOU SHOULD INSPECT THE BURNER VENTURI TUBES FOR SPIDER WEBS AND OTHER OBSTRUCTIONS PERIODICALLY. CLEAN TUBES COMPLETELY IF YOU FIND ANYTHING. A CLOGGED TUBE CAN LEAD TO A FIRE BENEATH THE GRILL.

**NOTICE:** NEVER PLACE FOOD OVER A BURNER THAT IS NOT IN OPERATION. FOOD DRIPPINGS WILL NOT BE INCINERATED AND THE BURNER PORTS MAY BECOME CLOGGED. THE BURNER SHOULD NOT COME IN CONTACT WITH WATER OR OTHER CLEANING FLUIDS BECAUSE THEY MAY DAMAGE THE BURNER, CAUSING IT TO FUNCTION IMPROPERLY.

The Patio II™ grill is equipped with a pilot burner. This safety feature will re-ignite the burner if it goes out while you are cooking. Pilot burners take a certain amount of time to ignite because gas must first flow from the gas cylinder to the pilot tip. When lighting the pilot, be sure to use the following instructions.

## Burner Ignition

### Procedure:

1. Open the Hood, ensure all valves are closed and that the cooking surface of the grill is not covered.
2. For LP gas, open the Gas Cylinder Valve by turning the Handwheel counter-clockwise. (See Figure 8.) Then, wait 15 seconds prior to Step 3.  
For Natural gas, open the gas valve in the main line.
3. Depress and turn the Pilot Output Knob to  (ON).

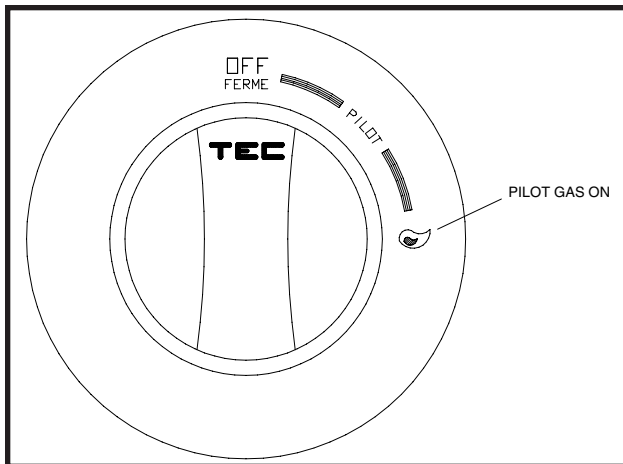



Figure 9. Pilot Output Knob

4. Slowly rotate the Ignitor Knob clockwise twice and check for pilot flame. If a flame is not present, turn the Pilot Output Knob to OFF and wait 5 minutes. Then repeat steps 3 and 4.
5. Depress and turn the Burner Output Knobs to  (HIGH). If burners do not ignite within 5 seconds, turn Burner Output Knobs to OFF and wait 5 minutes, and repeat.
6. Operate on  (HIGH) until burners glow uniformly, then turn the Burner Output Knobs to the desired cooking level.
7. To extinguish the flame, depress and rotate the Burner Output Knobs and the Pilot Output Knob to OFF.
8. For LP gas, close the Gas Cylinder Valve by turning the Handwheel clockwise. For Natural gas, close the gas valve in the main line.

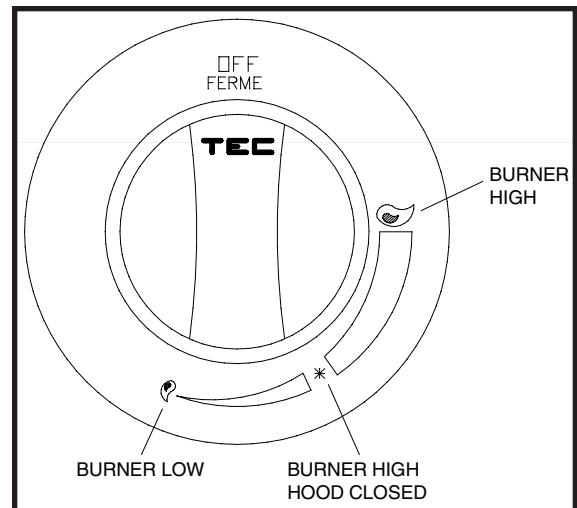

Figure 10. Burner Output Knob

**CAUTION:** WITH THE HOOD CLOSED, THE BURNER OUTPUT KNOB POSITION MARKED \* IS THE MAXIMUM TEMPERATURE SETTING TO BE USED. THE BURNER OUTPUT SHOULD NEVER BE INCREASED BEYOND THIS POSITION WITH THE HOOD CLOSED.



## Burner Ignition Without Pilot

If your pilot/spark ignition system is not working properly, the burner may be ignited manually, using a match. Use the following procedure to do so.

**CAUTION:** DO NOT HOLD A MATCH IN YOUR HAND ABOVE THE SCREEN WHEN LIGHTING THE BURNER MANUALLY. PLACE THE MATCH DIRECTLY ON THE BURNER SCREEN, THEN PULL YOUR HAND AWAY FROM THE GRILL..

# Operation continued

## Procedure:

1. Open the Hood, ensure all valves are closed and that the cooking surface of the grill is not covered.
2. For LP gas, open the Gas Cylinder Valve by turning the Handwheel counter-clockwise. (See Figure 8.)  
For Natural gas, open the gas valve in the main line.
3. Remove the right cooking grid. Ignite the match. Place the match directly on the burner screen above the right half of the burner.
4. Confirm that the match is still burning. Depress and turn the right Burner Output Knob to  (HIGH). Once it is lit, depress and turn the left burner to  (HIGH). If either burner fails to ignite within 5 seconds, turn the Burner Output Knob of that burner to OFF, wait five minutes, then repeat.
5. Operate on  (HIGH) until the burners glow uniformly, then turn the Burner Output Knobs to desired cooking level.
6. To extinguish the flame, depress and rotate the Burner Output Knobs and the Pilot Output Knob to OFF.
7. For LP gas, close the Gas Cylinder Valve by turning the Handwheel clockwise. For Natural gas, close the gas valve in the main line.

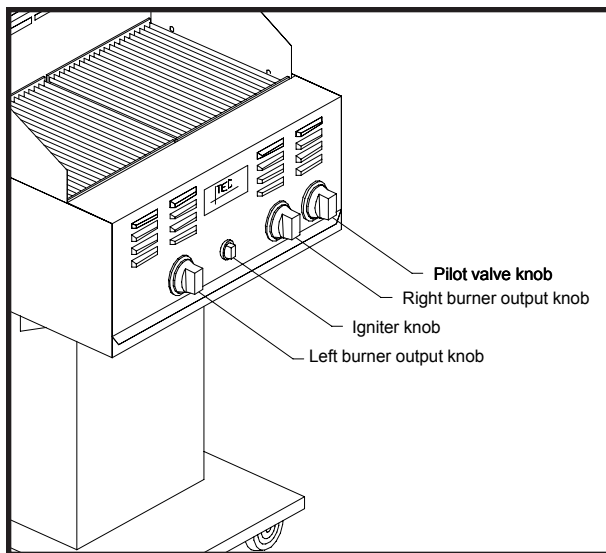

**Figure 12.** Burner and Pilot Output Knobs

## Low Heat Adjustment

**WARNING:** NEVER ADJUST THE BURNER SO LOW THAT IT MAY GO OUT DURING USE. DO NOT OPERATE GRILL WITH DISENGAGED LOW HEAT ADJUSTING SCREW.

The Low Heat Adjusting Screw only applies to the burner operation at the LOW setting. Other settings are not affected by this adjustment. Any efforts to make adjustments at another setting will produce no change in the flame until the burner is turned to LOW. If the burner is adjusted too low, it may involuntarily extinguish while gas is still flowing. This condition is unsafe, therefore adjustments should only be made with the Burner Output Knobs positioned at the LOW setting while paying careful attention to resulting changes in burner performance.

The burner's LOW heat output is preset at the factory. If your atmospheric conditions or altitude are significantly different from those existing in our factory, the burners may operate differently than they did at our factory. This may warrant adjustment of the low heat settings. Also, you may simply desire to change it because of your cooking style. To complete the LOW Heat Adjustment, follow the instructions below.

## Procedure:

1. Follow the Burner Ignition procedures and operate the grill for 5 minutes or until the burners glow uniformly throughout.
2. Turn the Burner Output Knob of the burner to be adjusted to the LOW position and wait until the temperature drops and stabilizes.
3. Remove the Burner Output Knob from the valve stem. (See Figure 12.)
4. Insert a  $\frac{1}{8}$ " blade screwdriver into the valve stem.
5. Turn the Low Heat Adjusting Screw clockwise to reduce the LOW heat intensity or counter-clockwise to increase the LOW heat intensity.

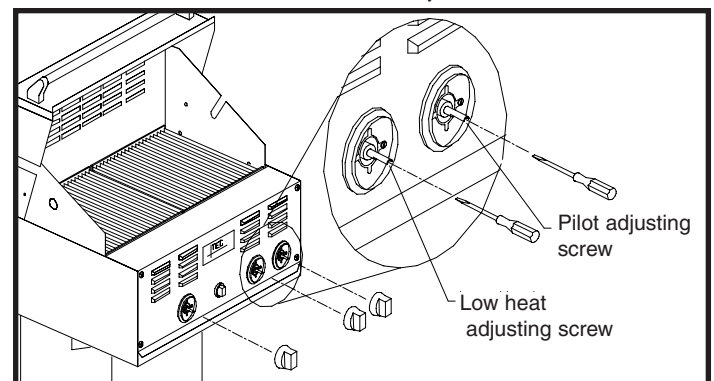

**Figure 12a.** Low Heat Adjustment

# Operation continued

## Pilot Flame Adjustment

The pilot flame length is preset at the factory, but can be adjusted. The flame length should be approximately one inch from the hood covering the pilot burner. Make sure the burner is not in operation and that all other gas valves are OFF prior to adjusting the pilot. This procedure should not be performed while the grill is hot. Use a small 1/8" flat-blade screwdriver and the following procedure to make pilot adjustments.

### Procedure:

1. Ignite the pilot following Steps 1 through 4 of the Burner Ignition Procedure.
2. Remove the Pilot Output Knob from the valve stem.
3. Insert a 1/8" flat blade screwdriver into the valve stem.
4. While visually observing the pilot flame, rotate the pilot adjustment screw counter-clockwise to increase the flame length or clockwise to decrease the flame length. The flame should be approximately one-inch long. (See Figure 13.)

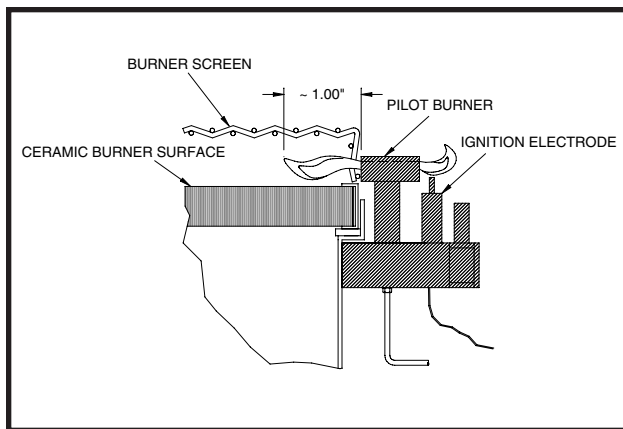
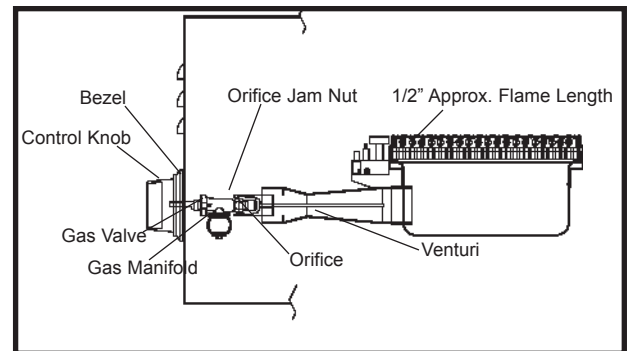

**Figure 13.** Pilot Light Adjustment

### Burner Flame

The burner flame should be approximately 1/2" tall when the burner is in operation (See Figure 13a).

**WARNING:** EACH GAS ORIFICE MUST BE PROPERLY LOCATED ON THE ORIFICE BRACKET, ATTACHED TO THE VENTURI ON THE BURNER ASSEMBLY. AN IMPROPERLY LOCATED ORIFICE CAN LEAD TO BODILY INJURY AND PROPERTY DAMAGE. THE PROPER LOCATION IS SHOWN IN FIGURE 13A.



**Figure 13a.** Burner Flame and Orifice Location

## Hazardous Locations and Conditions

- When cooking, keep your grill at least one foot from combustible surfaces (wood wall or wooden fence, etc.) and from under combustible material (i.e. wood, canvas, plastic, etc.).
- Do not block the flow of combustion and ventilation air.
- Only use your grill outside in a well-ventilated area. Do not cook in a building, garage, or other enclosed area.
- Keep flammable substances away from the grill, including spare gas cylinders, aerosols and aerosol containers, gasoline and similar liquids, paper and paper products, containers of grease, paint, etc.
- Never leave your grill unattended while it is on.
- Never use water to control a flare-up.
- Do not wear flammable and/or loose clothing, such as neckties, scarves, etc., while using the grill.

# Infra-Red Cooking

## Sample Cooking Methods

Unless otherwise noted, these cooking guidelines require *cooking with hood open*. Use this chart as a cooking guide. *Cooking times may vary, depending on thickness of food.*

<b>FOOD</b>	<b>CONTROL SETTING</b>	<b>TOTAL COOKING TIME</b>
<b>Steak 1" Thick</b>	High fire 2 min. each side	4 min. - Rare
	High fire 2 min. each side. Balance "medium" fire	6 min. - Medium
	High fire 2 min. each side. Balance "medium" fire	8 min. - Well Done
<b>Hamburger 1/2" Thick</b>	High fire 2 1/2 min. each side	5 min. - Medium
	High fire 3 min. each side	6 min. - Well Done
<b>Chicken - Parts</b>	High fire, 2 min. per side	20 to 25 min.
	Balance medium low to low fire	
<b>Chicken Breast 3/4" Thick, Filleted</b>	High fire, 2 min. each side	8 to 10 min.
<b>Hot Dogs</b>	Medium-Low	4-6 min.
<b>Pork Chops</b>	Medium	6 min. per side
<b>Spare Ribs</b>	High fire 5 min.	20 min. per side
	Low to finish	Turn often
<b>Lamb Chops</b>	High fire 5 min.	15 min. per side
	Medium to finish	
<b>Fish 1 lb.</b>	Medium-Low	6-8 min. per side
<b>Shrimp, Shelled</b>	Medium-Low	3-4 min. per side
<b>Kabobs</b>	Medium-Low	4-5 min. per side (2 sides)
<b>COOK WITH HOOD CLOSED</b>		
<b>Potatoes</b>	Medium-Low	45-60 min. per side
<b>Corn on the Cob</b>	Medium-Low	20-30 min. per side
<b>Onions</b>	Medium-Low	20-30 min. per side
<b>Lobster 1-1 1/2 lbs.</b>	Medium-Low	15 min. per side
<b>COOK ON ROTISSERIE WITH HOOD OPEN</b>		
<b>Chicken - Whole</b>	High fire 10 min. Balance "medium" fire	1 hour, 20 min.
<b>Rib-eye Roast</b>	High fire 10 min. Balance "medium" fire	15 min./lb. - Rare
		20 min./lb. - Medium
		25 min./lb. - Well Done
<b>Pork Roast</b>	High fire 10 min. Balance "medium" fire	Always cook well done
		25 min./lb
<b>Turkey 12-13 lbs.</b>	Low fire, <i>Cook with hood closed</i>	3 hours, 30 min. until 175°F internal temp.

# Infra-Red Cooking continued

## General Overview

TEC Infra-Red gas grills make it possible for you to enjoy cooking outdoors quickly and effortlessly. In minutes, you can enjoy steaks, hamburgers, poultry, pork chops, fish and other foods. You can also cook more slowly if you wish. TEC's optional accessories are designed to enhance your grill's versatility. (See Appendix A.)

## Infra-Red Searing Method

Searing is a process that seals juices in food by cooking with intense heat for a short period of time. The juices stay in the food where they belong and the outside gets coated with flavorful smoke. For best results, follow these procedure when cooking.

### Searing Method

1. Follow the Burner Ignition procedures and operate the grill for 5 minutes or until the burners glow uniformly.
2. Set the Burner Output Knob to HIGH and place the food on the Cooking Grid for 1-2 minutes, or until food lifts without sticking.
3. Turn the food and repeat Step 2.
4. Depending upon your taste, continue cooking on HIGH, turning the food frequently, or adjust the Burner Output Knob to a setting between LOW and "medium" and continue cooking until the food is cooked to your satisfaction. Turn as necessary (generally every one to three minutes).

During the searing period, flashing might occur when juices vaporize on contact with the Cooking Grid and burner surfaces. The flashes and smoke greatly enhance the flavor of food.

The intense Infra-Red energy generated by your TEC grill has other advantages. For example, food is evenly cooked throughout. Also, upon contact with the Cooking Grids and burners, drippings vaporize into flavorful smoke that cooks back into the food.

## Helpful Hints in Maintenance and Cooking

1. Cover the Drip Tray with foil. Be careful not to cover the ventilation openings at front of the Drip Tray. This helps with clean-up, too.
2. Line the inner walls of the Heat Shield with foil.
3. Use the proper tools. Long handled tongs, spatula,

knife, and mitts or a hot pad for handling hot items. When turning or moving foods, use tongs or a spatula, instead of a fork. Piercing the food with a fork allows the natural juices and flavor to escape.

4. Monitor meat temperature. Bring large cuts of meat, roast, or fowl to room temperature before cooking. Smaller meat cuts such as hamburgers, wieners, or small steaks may be cooked directly from the refrigerator. Note: TEC does not recommend cooking portion meats from a frozen state.
5. Start Slowly. Infra-Red grilling is unlike other outdoor cooking methods. It may take time to get used to the fast cooking process. As a benchmark, foods which generally cook in 20 minutes or less on conventional grills cook in about one-half the conventional time on a TEC Infra-Red grill. Please refer to the Sample Cooking Times and Settings below.

## Flare-Up Control

**NOTICE:** NEVER DOUSE A FLARE-UP WITH WATER. IT WILL DAMAGE THE BURNER!

To minimize flame flare-ups:

- Use the Cooking Grids with the U-shape channels facing up.
- Trim excess fat from meat.
- Preheat the grill for 3 minutes before each use.
- Reduce heat and reposition foods away from flare-ups when they occur.
- Prevent excess grease build up by periodically cleaning Cooking Grids.



# Care, Cleaning and Maintenance

## General Overview

Proper care, maintenance and cleaning will help ensure a long life for your grill. Periodic cleaning will help avoid accumulations of flammable grease and other debris.

Because of the high intensity of the Infra-Red burner, any drippings and food particles that fall onto the burner surface are immediately incinerated. However, some debris and residue may remain. To remove this residue after cooking, turn the grill on HIGH for 5-10 minutes with the hood OPEN.

## Protection of Burners

The burners of your grill are designed to provide a long life of satisfactory performance. However, there are steps you must take to prevent cracking of their ceramic surfaces, which will cause the burners to malfunction. Following are the most common causes of cracks and the steps you must take to avoid them. **Damage caused by failure to follow these steps is not covered by your grill warranty.**

**IMPACT WITH HARD OBJECTS** - Never allow hard objects to strike the ceramic. You should take particular care when inserting or removing Cooking Grids and accessories into or from the grill. If objects such as these fall onto the ceramic, it is likely to crack the ceramic.

**IMPAIRED VENTILATION OF HOT AIR FROM THE GRILL** - In order for the burners to function properly, hot air created by the burners must have a way to escape the grill. If the hot air is not allowed to escape, the burners may become deprived of oxygen, causing them to backfire, especially if the burner output is set at HIGH. If this occurs repeatedly, the burners may crack. This is the reason your grill was designed with ventilation louvers, and the accessories were designed to leave open space at the grill surface. These design features give the hot air an escape route. Accordingly, never operate your grill with very little or no open space at the cooking surface (the Cooking Grids provide sufficient open space).

Also, never cover the ventilation louvers with foil or other materials that prevent air flow. Specifically:

- Do not operate the grill on high fire with the hood closed. The Burner Output Knobs indicate the maximum gas setting ★ you can use with the hood closed. (See Figure 10 on page 10.)

- Do not use accessories in combinations that cover more than 75% of the cooking surface with solid metal. For example, on a two-burner unit, do not use the deep fryer/steamer over one burner and a griddle over the other burner simultaneously. Leave one side open. Appendix A, Accessories, contains further instructions as to proper accessories use and warnings about improper use.

- Do not cover the entire surface with aluminum foil, a large pan, etc.

**WATER OR OTHER LIQUIDS** - When the burners are in operation, their intense heat is normally sufficient to vaporize any drippings, marinades or sauces that contact the surface as a byproduct of grilling. This does not include water thrown into the grill to douse a flame. Cold liquid contacting a hot surface in substantial amounts can cause the surface to break. Also, if the ceramic or interior of a burner becomes wet while not in use, later operation of the burner can create steam, which may produce enough pressure to crack the ceramic. In addition, repeated soaking of the ceramic will cause it to swell and expand. This expansion will create pressure on the ceramic and cause it to crack and crumble.

To prevent burner damage caused by liquids, please do the following:

- Never throw water into the grill to control a flare-up.
- Never expose the burners to the risk of soaking by rainfall, sprinklers or otherwise. We recommend that you keep your grill covered with a heavy duty vinyl cover at all times when it is not in use. Your dealer should have TEC covers designed specifically for your grill for this purpose. Further, do not attempt to operate your grill in the open air while it is raining. Finally, after you use the grill, close the hood as soon as you turn the burners off so that, if it rains, the burners will not be exposed to direct rainfall while the grill is cooling.
- If you find standing water in your grill (because of exposure to rainfall, etc.), examine the ceramic burner surfaces for evidence of possible water soaking. If the ceramic appears to be wet, remove the burners from the grill and turn them upside down to empty any water from the burner box. After draining all the water, place the burners indoors and allow it to dry thoroughly. Also, empty any water standing in the grill's Drip Tray. Then, reinstall the burners. After

# Care, Cleaning and Maintenance continued

testing for gas leaks around all fittings as described in Gas Leak Test on page 9, you should be able to resume normal use of your grill.

## Cleaning

**CAUTION:** ALWAYS ALLOW THE GRILL TO COOL BEFORE CLEANING. DO NOT LET WATER COME IN CONTACT WITH THE BURNER SURFACE AT ANY TIME.

### Drip Tray

Remove soiled foil and rinse with soap and water. Re-cover the Drip Tray with foil.

### Heat Shield

Remove soiled foil and re-cover. If necessary, the Heat Shield may be removed for further cleaning.

### Cooking Grids

Leave the Cooking Grids in place for 5-10 minutes while the burner is on HIGH with the hood OPEN. The Cooking Grids may also be removed and cleaned with a brass or stainless steel bristle brush and soapy solution. Standard oven cleaners may be used for further cleaning. Rinse the Cooking Grids thoroughly with clean water before using.

## Maintenance

The Patio II™ requires very little maintenance. However, a periodic inspection of orifice openings and venturi inlets to clear obstructions to gas flow is recommended.

### Burner Head

To maintain the performance of the Infra-Red burner it is important to operate the grill on HIGH for at least 5 minutes after each use.

This procedure will leave some ash on the surface of the Burner Head. If it accumulates in excessive amounts, it will clog the small ports in the ceramic surface. To prevent this blockage, remove the Cooking Grid and the Burner Screen, and vacuum the burner surface with a low-suction vacuum cleaner every six months, or as necessary. When completing this procedure be careful not to scrape or strike the ceramic with the suction device, which may damage the ceramic.

## Replacement Parts

If you need replacement parts or accessories, contact your TEC authorized dealer. See Appendix C of this manual for a listing of replacement parts and accessories.

## Heat Shield Removal Procedures Tools Required

- $\frac{5}{16}$ " hex-head nut driver or wrench
- #2 Phillips-head screwdriver

Follow the steps below to remove the Heat Shield. (See Figure 15.)

1. Remove the (4) four Phillips-head screws from the front panel of the grill.
2. Remove the front panel.
3. Remove (2) two hex-head screws from the work shelf.
4. Remove the work shelf.
5. Remove (4) four hex-head screws from the grill hood assembly.
6. Remove the grill hood assembly.
7. Lift the Heat Shield out of the grill housing.

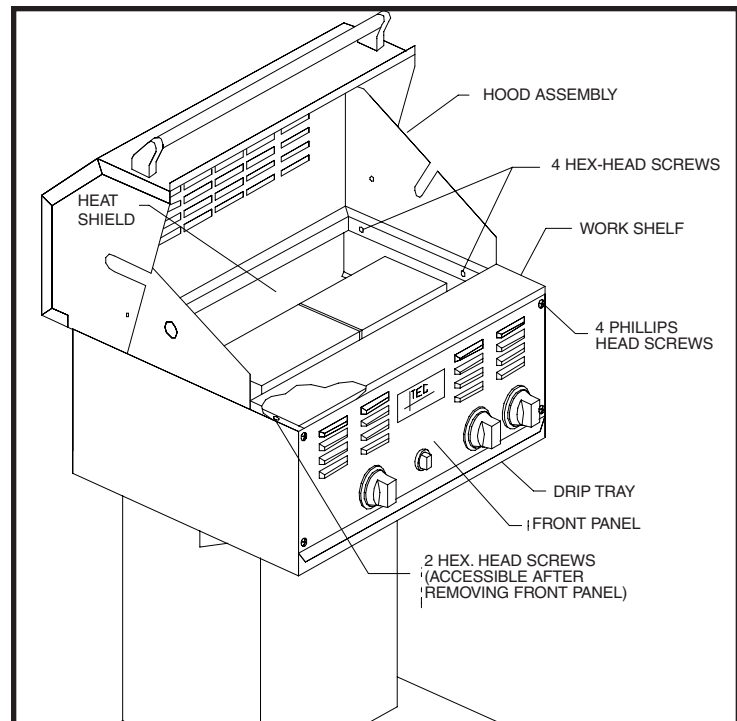

**Figure 15.** Heat Shield Removal

# Appendix A: Accessories

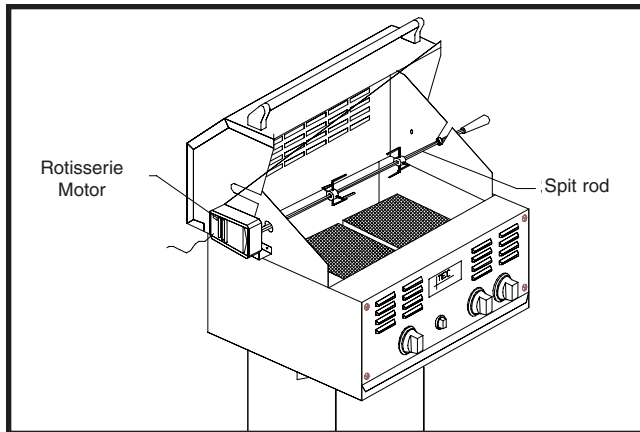

**Figure 16.** Rotisserie

## Rotisserie

Cooking versatility is a trademark of TEC grills. With the Rotisserie, you can add a new and exciting dimension to cooking. The Rotisserie can be used in direct Infra-Red cooking or with the Bar-B-Que Tray (a deflector pan) for indirect Infra-Red cooking.

## Installing The Rotisserie

### Tools Required

■  $\frac{3}{8}$ " wrench

■ Flat-head screwdriver

1. Attach the Rotisserie Bracket to the stationary hood wall with two (2) 10-24 x  $\frac{1}{2}$ " screws and two (2) keps nuts (supplied).
2. Position the Rotisserie Motor on the Rotisserie Bracket and plug it into a grounded outlet.

### Rotisserie Use

**CAUTION:** DO NOT USE THE ROTISSERIE IN THE RAIN.

1. The Cooking Grids may be removed or left in place.
2. Ignite the Burners in accordance with the Burner Ignition Procedures on Page 10.
3. Position the spit-rod in center of the meat, and tighten the forks into the ends of the meat. Make sure the meat is evenly balanced on the rod. Turn the Rotisserie ON.
4. You may cook with the hood open or closed. If you close the hood, do not turn the temperature up

higher than the ★ position indicated on the Burner Output Knobs, and monitor the food to ensure it is not overcooking.

5. After cooking, be sure to turn both burners to OFF. For best results, refer to the Infra-Red Cooking section of this manual.

The TEC Rotisserie has not been tested by the American Gas Association or the Canadian Gas Association.

## Appendix A: Accessories continued

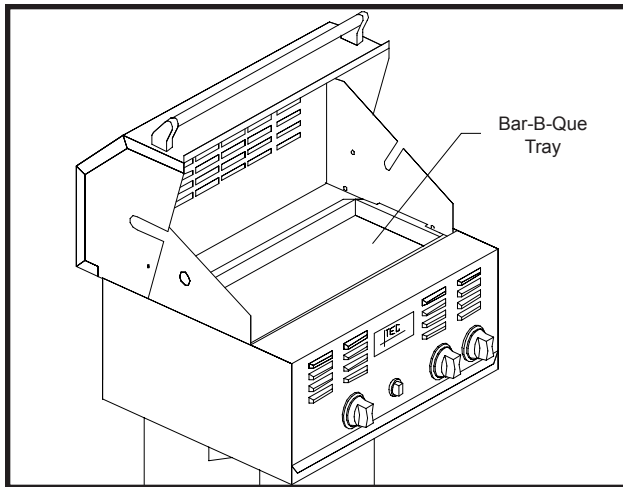

**Figure 17.** Bar-B-Que Tray

The TEC Bar-B-Que Tray has not been tested by the American Gas Association or the Canadian Gas Association.

### Bar-B-Que Tray

The primary purpose of the Bar-B-Que Tray is to deflect the Infra-Red heat so that it does not contact the food directly. This permits slower cooking primarily with a convection cooking process. It also catches excess drippings, eliminating flare-ups. You can use the Bar-B-Que Tray in conjunction with the Rotisserie or the Baking Tray for slower cooking and unique flavoring.

#### Bar-B-Que Tray Use

1. Remove both Cooking Grids.
2. Place the Bar-B-Que Tray in the grill, suspending it from side to side. **Water or wine should be added to the Bar-B-Que Tray to prevent it from warping. Repeat this throughout the cooking process so that liquid level is maintained. Be careful not to spill liquid onto the burners.**
3. The Cooking Grids may be replaced or left out.
4. Ignite the Burners in accordance with the Burner Ignition Procedures on Page 10.
5. Turn the Burner Output Knobs to the desired temperature.
6. For best results, close the hood. If you close the

hood, make sure the temperature is no higher than the ★ position indicated on the Burner Output Knobs.

7. For the lowest amount of heat, turn one burner to OFF and the other burner to LOW.
8. After cooking, be sure to turn both burners to OFF. Allow the grill and Bar-B-Que tray to cool before attempting to remove the Bar-B-Que tray.

## Appendix A: Accessories continued

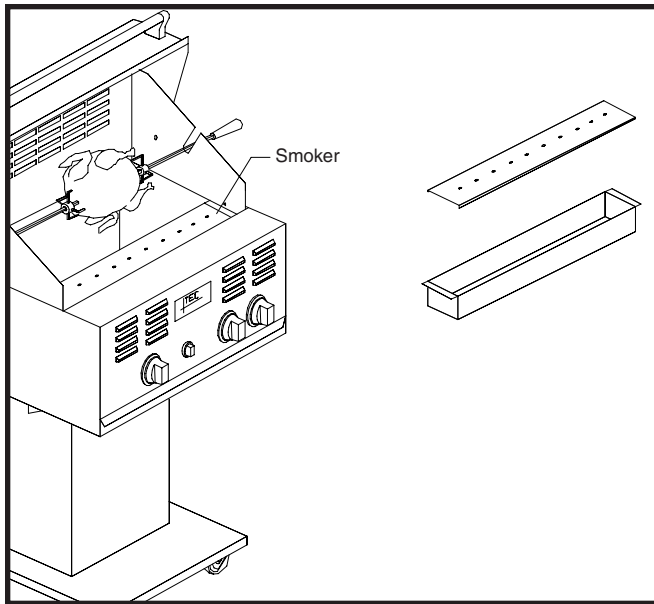

**Figure 18.** Wood Chip Smoker

The TEC Wood Chip Smoker has not been tested by the American Gas Association or the Canadian Gas Association.

## Wood Chip Smoker

With the Wood Chip Smoker, delicious smoked flavor can enhance the taste of foods. Damp hickory and maple wood chips have been used to enhance the flavor of meat for years, but you can create your own flavors by using various types of seasonings such as cloves, garlic or bay leaves.

### Wood Chip Smoker Use

1. Fill the Smoker with wood chips.
2. Add water and let the chips soak for at least 30 minutes and preferably for several hours or overnight.
3. Drain the liquid from the Smoker.
4. Remove the Cooking Grids.
5. Place the Smoker on the front portion of burner.
6. Reposition the Cooking Grids.
7. Follow the Burner Ignition procedures and operate the grill for 5 minutes or until the burners glow uniformly.
8. Turn the Burner Output Knobs to LOW.
9. For best results close the hood. If you close the hood,

make sure the temperature is no higher than the ★ position indicated on the Burner Output Knobs.

10. After cooking, be sure to turn both burners to OFF. Allow the grill and Smoker to cool before attempting to remove Smoker.

## Appendix A: Accessories continued

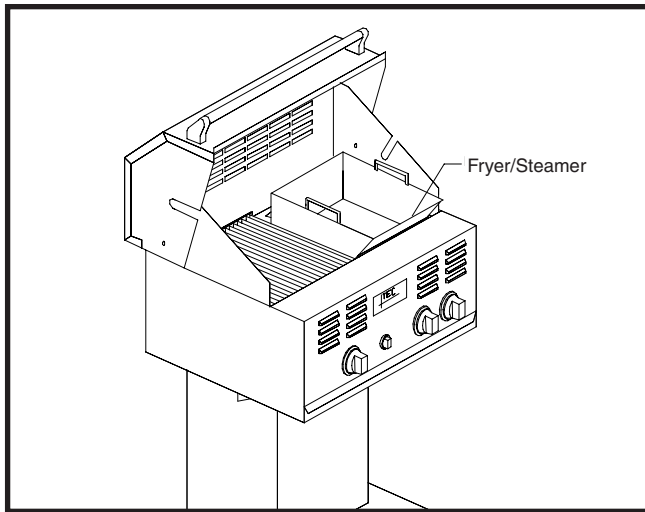

**Figure 19.** Deep Fryer

### **WARNING:**

1. In the event of rain while cooking with oil / grease, cover the cooking vessel immediately and turn off the appliance burner and gas supply. Do not attempt to move the appliance or cooking vessel.
2. When cooking with oil / grease, do not allow the oil/grease to exceed 350°F (177°C). Do not store or use extra cooking oil in the vicinity of this or any other appliance.
3. Do not leave oil / grease unattended.

**For your safety and the protection of your property keep a class A,B,C & D fire extinguisher on hand in case an oil fire occurs during use of this attachment.**

## Deep Fryer/Steamer

The Deep Fryer lets you cook foods that have been traditionally limited to indoor cooking. It's great for frying chicken, french fries, shrimp or fish; for boiling corn or potatoes and for cooking stews. The Steamer attachment is great for steaming vegetables like broccolli, new potatoes, carrots or cauliflower. It is also ideal for seafood such as shrimp, clams and oysters.

## Deep Fryer Use

Refer to Figure 19.

**CAUTION:** DO NOT CLOSE HOOD WHILE USING THIS ATTACHMENT FOR FRYING. HOT COOKING OIL CAN CAUSE BURNS. ALWAYS WEAR OVEN MITTS WHEN USING THE DEEP FRYER AND USE EXTREME CAUTION WHEN HANDLING HOT COOKING OIL OR WATER. DO NOT OPERATE YOUR GRILL WITH THIS ACCESSORY IN COMBINATION WITH OTHER ACCESSORIES, SUCH AS THE FRYING GRIDDLE OR OTHER OBJECTS THAT COVER MOST OF THE REMAINING COOKING SURFACE. ALWAYS LEAVE 25% OF THE SURFACE OPEN FOR VENTILATION.

OIL WILL BURN IF OVERHEATED. DO NOT LEAVE UNATTENDED WHILE HEATING. IF SMOKING OCCURS, REDUCE HEAT. IF OIL CATCHES FIRE, TURN OFF HEAT AND EXTINGUISH WITH A CLASS A,B,C & D FIRE EXTINGUISHER, OR COVER FRYER WITH STEAMER LID UNTIL COOLED. DO NOT PUT WATER ON HOT OR FLAMING OIL!

1. Remove the Cooking Grid over the burner that will be used to operate the Deep Fryer/Steamer. It does not matter which burner you use for this.
2. After removing the Steamer attachment, place the Deep Fryer/Steamer over the desired burner.
3. Fill the Deep Fryer/Steamer one-third full with cooking oil or water (one-gallon). DO NOT OVERFILL.
4. Ignite the burner in accordance with the Burner Ignition Procedures on Page 10.
5. Operate the burner on high for a total of approximately 4 to 8 minutes to properly heat cooking oil or water, then reduce heat. We suggest you use a candy thermometer (supplied) to check the temperature of the oil or water. However, do not rely on the thermometer readings in lieu of observing the cautions and warnings in this manual. You must remain alert for signs of over-heating and take steps to avoid an oil fire.
7. Let the left burner stay on HIGH for 4 to 8 minutes to properly heat cooking oil or water. We suggest you use a candy thermometer to check the temperature of the oil. Normally, 325° F to 350° F is sufficient for frying.
8. Turn burner Control Dial between "medium" and

## Appendix A: Accessories continued

LOW. Do not leave the burner on HIGH for an extended period.

9. Place the food into Deep Fryer/Steamer with long-handled utensils, being careful not to allow the oil to splash out of the Deep Fryer.
10. After cooking, turn the burner(s) to OFF. Let the grill and cooking oil or water cool to room temperature before attempting to remove the Deep Fryer/Steam

### Steamer Use

**CAUTION:** STEAM CAN CAUSE SERIOUS BURNS. ALWAYS WEAR OVEN MITTS. USE EXTREME CAUTION WHEN REMOVING STEAMER LID.

Refer to Figure 20.

1. Remove the Cooking Grid over the burner that will be used to operate the Deep Fryer/Steamer. It does not matter which burner you use for this.
2. Place the Deep Fryer/Steamer over the desired burner.
3. Fill the bottom of the Container with 1 gallon of water.
4. Place the Steamer Screen in the bottom of the Container. Cover with the lid.
5. Follow the instructions for operation under Frying and Boiling.
6. Let the water come to a boil.
7. Remove the lid and add the food.
8. Cook until desired texture is attained.
9. After cooking, turn the burners to OFF. Let the grill and water cool to room temperature before removing Deep Fryer/Steamer.

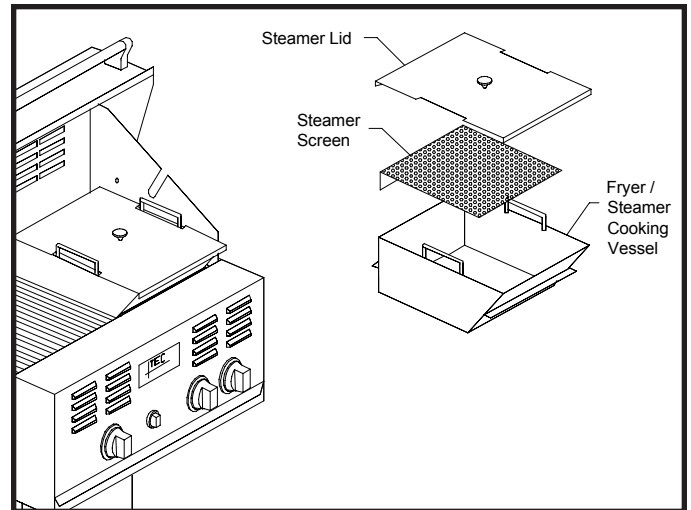

**Figure 20.** Steamer Attachment

The TEC Steamer has not been tested by the American Gas Association or the Canadian Gas Association.

## Appendix A: Accessories continued

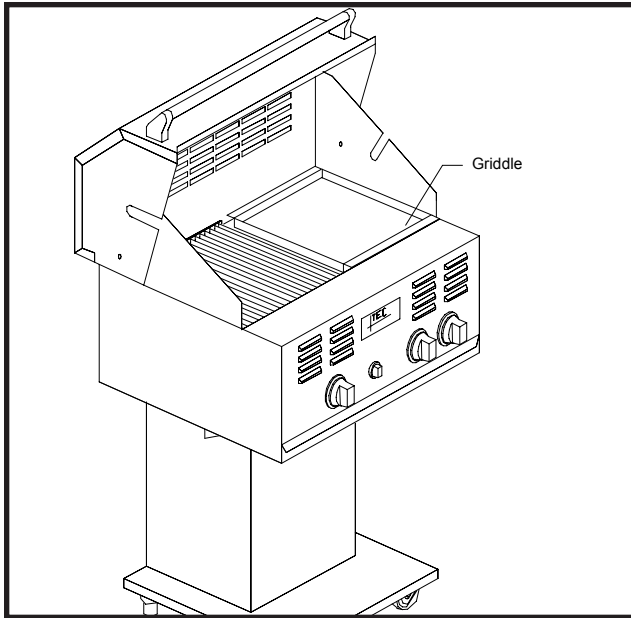

**Figure 21.** Griddle

The TEC Griddle has not been tested by the American Gas Association or the Canadian Gas Association.

### Griddle

This Griddle provides a surface for you to use your grill for pan frying foods such as bacon, eggs, sausage, french toast and pancakes, and for blackening fish and meats. It may be used over the right or left burner. **Before each use, the Griddle should be thoroughly washed (with warm soap and water), dried and rubbed with cooking oil to prevent rusting.**

**CAUTION:** DO NOT OPERATE THE GRILL USING THIS GRIDDLE IN COMBINATION WITH ANOTHER GRIDDLE, A DEEP FRYER/STEAMER OR ANY OTHER OBJECT THAT RESULTS IN COVERING MOST OF THE REMAINING COOKING SURFACE. ALWAYS LEAVE 25% OF THE COOKING SURFACE OPEN FOR VENTILATION.

### Griddle Use

Refer to Figure 21.

1. Remove the Cooking Grid over the burner that will be used to operate the Griddle. It does not matter which burner you use for this
2. Place the Griddle over the burner.

3. Ignite the Burner in accordance with the Burner Ignition Procedures on Page 10.
4. Adjust Burner Output Knob to between “medium” and “low” for frying or between “medium” and “high” for blackening.5. Turn the burners to OFF after cooking. Let the grill and Griddle cool to room temperature before attempting to remove the Griddle.



## Appendix A: Accessories continued

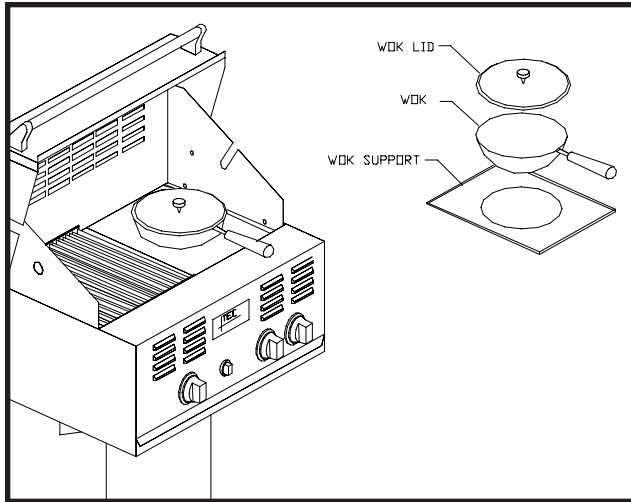

**Figure 22.** Wok

The TEC Wok has not been tested by the American Gas Association or the Canadian Gas Association.

## Wok

Enjoy stir-fry cooking on your TEC grill with the Wok accessory. Using high temperature, you can quickly cook chicken, beef, shrimp or assorted vegetables. It may be used over the RIGHT or LEFT burner.

## Wok Use

Refer to Figure 22.

1. Remove the Cooking Grid over the burner that will be used to operate the WOK. It does not matter which burner you use for this.
2. Place the Wok Support over the desired burner.
3. Place the Wok in the Wok Support.
4. Ignite the burner in accordance with the Burner Ignition Procedures on Page 10.
5. Adjust the Burner Output Knob to the desired heat setting.
6. After cooking, make sure the burners are turned to OFF. Let the Grill and Wok cool before attempting to remove the Wok.

## Appendix B: Replacement Parts List

PART NO.	DESCRIPTION
STBAN	.....Burner Assembly (less screen)
STBP	.....Burner Plate & Fiber Frax
STBS	.....Burner Screen
STBCV	.....Gas Valve, Burner
STPCV	.....Gas Valve, Pilot
STBK	.....Knob, Burner Output
STPK	.....Knob, Pilot Output
STIK	.....Knob, Ignitor
STCG	.....Cooking Grid (one)
P2DT	.....Drip Tray
ST30HH	.....Hood Handle Kit
ST30WR	.....Warming Rack
P2HS	.....Heat Shield
REG102	.....Regulator, w/hose, LP gas
ORI46	.....Orifice, Natural gas, #46
ORI55	.....Orifice, LP gas, #55
ST30IGN	.....Ignitor

# Appendix C: Troubleshooting

<b>PROBLEM</b>	<b>PROBABLE CAUSE</b>	<b>REMEDY</b>
Pilot will not light.	<ul style="list-style-type: none"> <li>a. Lack of gas.</li> <li>b. Obstruction in pilot orifice.</li> <li>c. Defective piezo ignitor.</li> <li>d. Dirty pilot electrode.</li> </ul>	<ul style="list-style-type: none"> <li>a. After turning Pilot Output Knob to ON position, wait approximately 20-30 seconds for air to purge gas supply line before turning ignitor knob. Fill LP gas cylinder, if applicable. Adjust pilot following the Pilot Flame Adjustment procedures outlined on Page 12.</li> <li>b. Clean pilot orifice.</li> <li>c. Replace piezo ignitor.</li> <li>d. Clean pilot electrode.</li> </ul>
Burner output at HIGH setting is too low. (Rumbling noise and fluttering blue flame at burner surface.)	<ul style="list-style-type: none"> <li>a. Lack of gas.</li> <li>b. Kinked regulator hose.</li> <li>c. Insufficient gas pressure despite ample gas supply.</li> <li>d. Dirty or clogged orifice.</li> <li>e. Venturi tube obstructed by spider webs, wasp nest, or other foreign matter.</li> <li>f. Cracked burner.</li> </ul>	<ul style="list-style-type: none"> <li>a. Check gas level in LP gas cylinder, if applicable.</li> <li>b. Reposition regulator hose, as necessary.</li> <li>c. Adjust regulator, as necessary.</li> <li>d. Clean burner orifice.</li> <li>e. Clean out all obstructions from venturi tube.</li> <li>f. Contact Authorized Dealer. Replace ceramic burner head.</li> </ul>
Burner output at LOW setting is too hot (or too cool).	<ul style="list-style-type: none"> <li>a. Low heat setting is adjusted too high (or too low).</li> </ul>	<ul style="list-style-type: none"> <li>a. Reduce (or increase) low heat setting following procedures on Page 11.</li> </ul>
Burner backfires (during operation burner abruptly makes a loud “woosh” sound, followed by a continuous blow-torch type sound and grows dim).	<ul style="list-style-type: none"> <li>a. Overloaded with grease drippings or build-up, clogging ports</li> <li>b. Burner overheated due to inadequate ventilation (too much cooking surface covered or operation of grill on high fire with hood closed).</li> <li>c. Cracked ceramic</li> <li>d. None of the above. Probable cause is leak in packing within or under ceramic burner head. Also can occur through breaks in welds of burner box. Both are manufacturer’s defects to which your warranty applies.</li> </ul>	<p>In all cases turn burner output knob to “OFF” position and let it cool for at least two minutes. Then:</p> <ul style="list-style-type: none"> <li>a. Relight burner and burn at a HIGH setting for at least five minutes or until ceramic glows uniformly.</li> <li>b. Remove any objects or accessories which may be covering more than 75% of the cooking surface. Allow the burner to cool for approximately two minutes, then relight the burner. <b>DO NOT OPERATE THE GRILL ON HIGH FIRE WITH HOOD CLOSED.</b></li> <li>c. Allow burner to cool and inspect very closely for cracks (which may be nearly invisible). If cracks are found, contact dealer to replace burner head.</li> <li>d. Contact authorized dealer. Packing under burner head should be replaced. If backfiring continues, burner box welds should be inspected for holes and/or burner head should be replaced.</li> </ul>

# Notes